

2003
VOLKSWAGEN JETTA ABS REMOVAL
FOR

ABS ITT
MARK 20 IE & ABS MARK 60

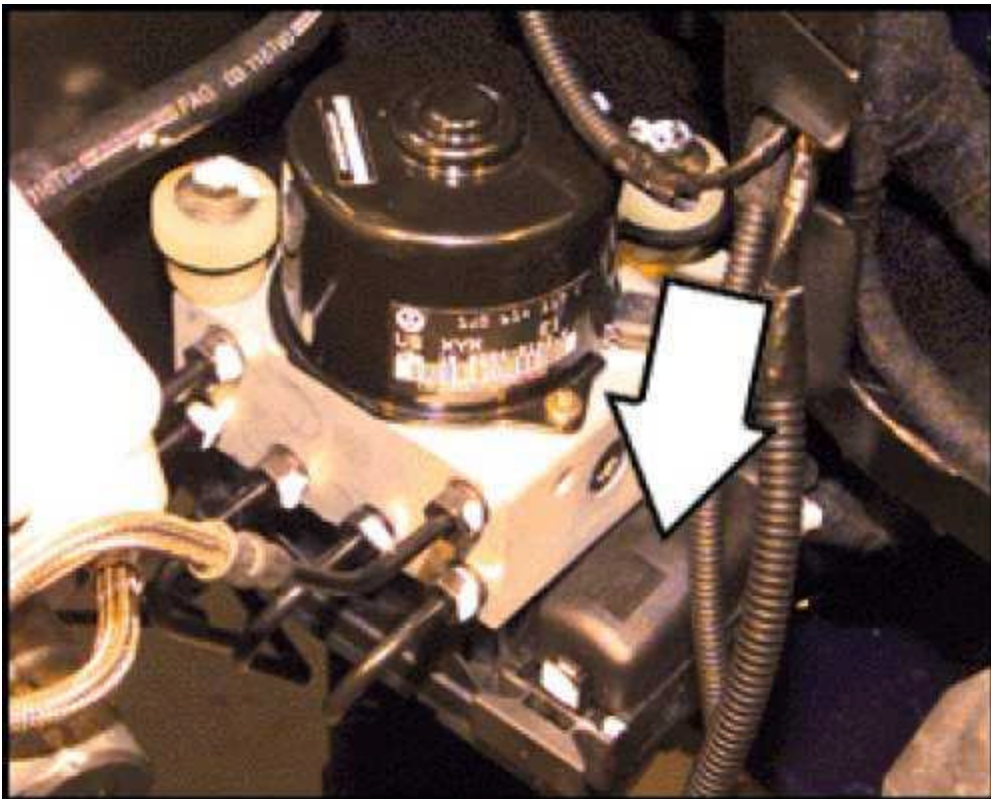

in engine compartment, to left of vacuum brake booster

- **component of ABS Hydraulic Control Unit**

ABS/EDL/ASR/ESP - Mark 60

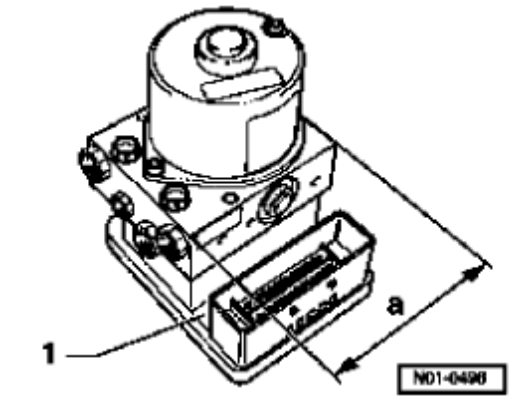

1. Control module, 47-pin (screwed to hydraulic unit). Two 4.8 mm wide contacts are located at both ends of the connection. The wiring linking between hydraulic unit and control module is routed internally.

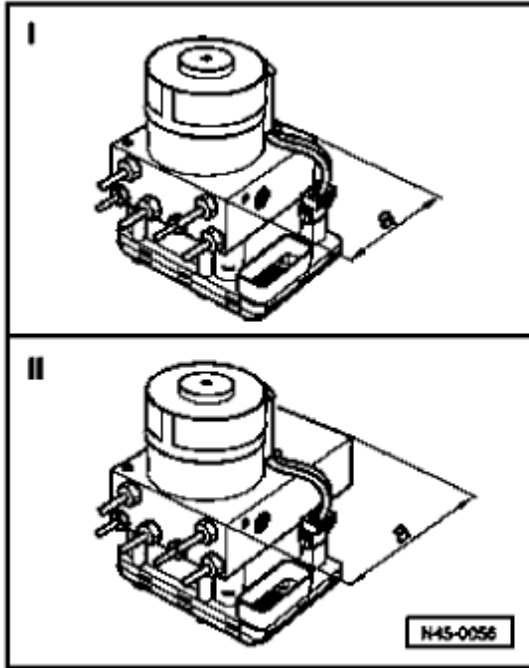

Distinguishing features of ABS ITT Mark 20 IE and the ABS/EDL ITT Mark 20 IE

I - ABS - ITT Mark 20 IE

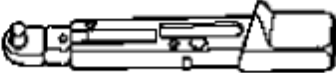

Hydraulic unit /ABS control module, removing and installing

Special tools and equipment

<p>V.A.G 1331</p> 	<p>V.A.G 1410</p> 
<p>V.A.G 1869/2</p> 	
	<p style="text-align: right;">W45-0003</p>

- VAG 1331 Torque wrench or equivalent
- VAG 1410 Torque wrench or equivalent
- VAG 1869/2 Brake pedal depressor or equivalent

Additional required information sources

Component location:

The ABS control module is bolted together with the hydraulic unit and is located in the engine compartment, left side.

CAUTION: Brake lines in the area of the hydraulic unit should not be bent!

Removing

- For vehicles with a coded radio, obtain code.

- Disconnect battery.

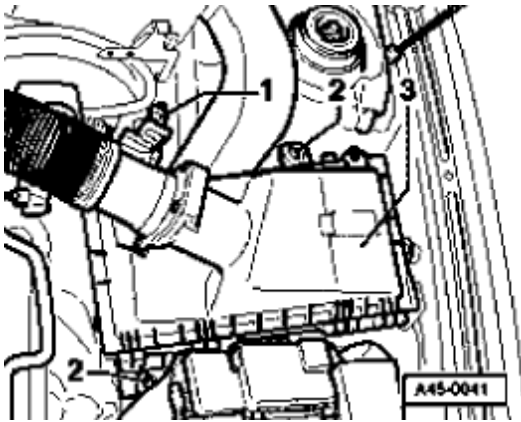

- Disconnect connector -1- of Mass Air Flow MAF sensor from air filter tube.
- Remove bolts -2- at air filter -3- and move filter to left side.
- On vehicles with Diesel engines, remove relay panel above brake booster.
- Remove as much brake fluid as possible from brake fluid reservoir using a brake bleeder bottle.
- Insert brake pedal depressor VAG 1869/2 or equivalent.
- Activate brake pedal booster with brake pedal depressor.
- Connect bleeder bottle hose to bleed screw of left front brake caliper and open bleed screw.
- Close left front bleed screw.

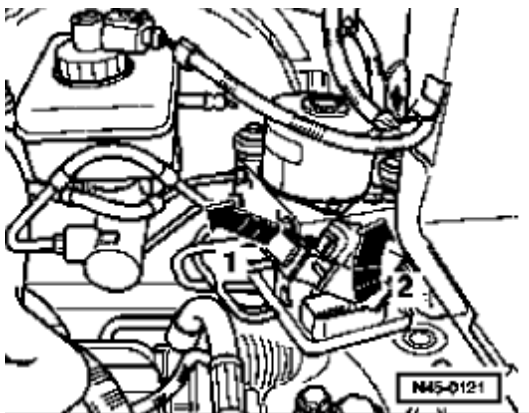

- Release ABS control module connector (arrow -1-) and remove (arrow -2 -)
- Place plastic covering under control module and hydraulic unit. Do not use rags.

Note: Do not let brake fluid enter electrical connectors.

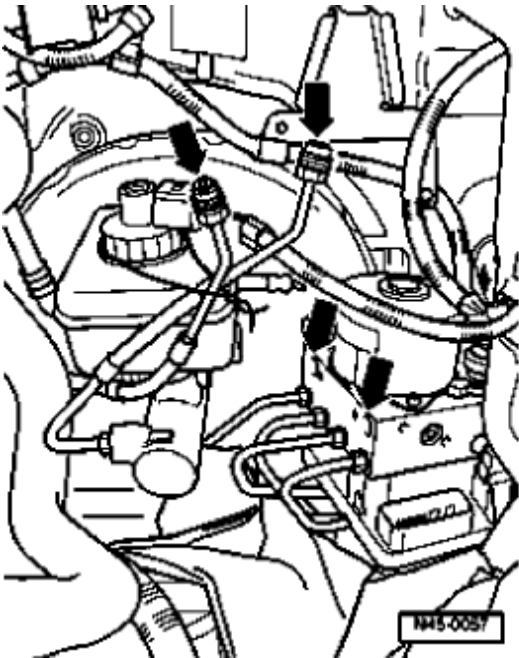

- Disconnect brake lines from hydraulic unit to [brake master cylinder](#) (arrows) and suspend with wire.
- Disconnect remaining brake lines from hydraulic unit.
- Seal brake lines and threaded holes (arrows) using plugs from repair kit, Part No. 1 HO 698 311 A.

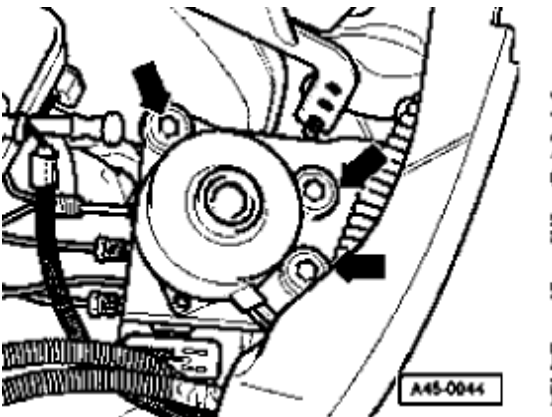

- Remove bolts from bracket for hydraulic unit (arrows).
- Remove hydraulic unit with control module.

ABS control module, removing from hydraulic unit

- Disconnect electrical connector for hydraulic pump motor from control module

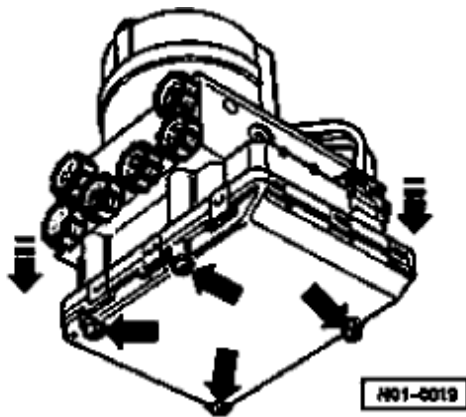

- Remove bolts (arrows) from control module and remove control module.

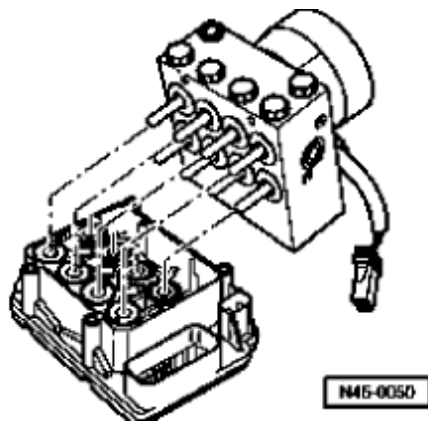

Note:

- When removing the control module make sure that the hydraulic unit valve dome does not contact the control module solenoid valves.
- Cover the control module magnet coils with a plastic cover. Do not use rags.
- After separating the control module and hydraulic unit use transportation protection for the valve dome.

Installing

Note:

- Only remove the sealing plugs on the new hydraulic unit just before installing the corresponding brake line.
- If the sealing plugs are removed from the hydraulic unit too early, brake fluid can escape. It can then no longer be guaranteed that the unit is sufficiently filled or adequately bled.
- When assembling the control module and hydraulic unit, be sure that the hydraulic unit valve dome does not come in contact with the control module solenoid valves.
- Using new bolts, install control module to hydraulic unit. Do not tighten

- Using new bolts, install control module to hydraulic unit. Do not tighten more than max. **4 Nm (35 inch lbs.)** .
- Re-connect electrical connector for hydraulic pump motor.
- Install ABS unit to bracket.

Note: Hand-tighten bolts at first to make attaching the individual brake lines easier.

- After tightening brake lines, tighten hydraulic unit.
- Continue installation in reverse order of removal.
- Bleed brake system
- Enter radio code.
- Code control module.

Tightening Torques:

Control module to hydraulic unit max.	4 Nm (35 inch lbs.)
Hydraulic unit to bracket	8 Nm (70 inch lbs.)
Nut for brake master cylinder to brake booster	20 Nm (15 ft. lbs.)
Brake lines at ABS unit:	
Thread M10 x 1	14 Nm (10 ft. lbs.)
Thread M12 x 1	14 Nm (10 ft. lbs.)
Nut to body	20 Nm (15 ft. lbs.)
Cap nut to body	20 Nm (15 ft. lbs.)

Control module and hydraulic unit Mark 60, removing and installing

Special tools and equipment

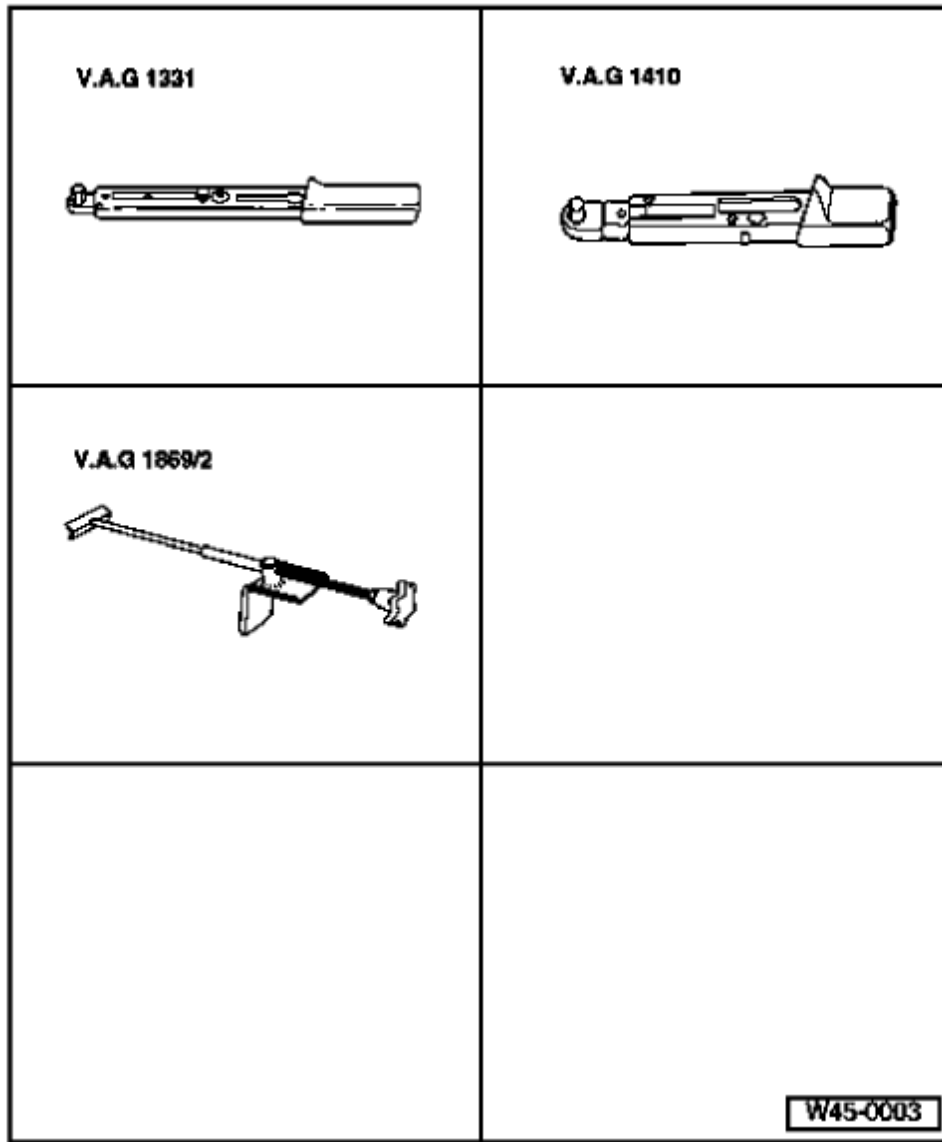

- VAG 1331 Torque wrench
- VAG 1410 Torque wrench
- VAG 1869/2 Brake pedal depressor

Location:

The control module is bolted to the hydraulic unit and is located on left in the engine compartment.

WARNING: Do not bend the brake lines in the area of the hydraulic unit!

Removing:

- Request radio code on vehicles with coded radio if necessary.
- Disconnect battery.

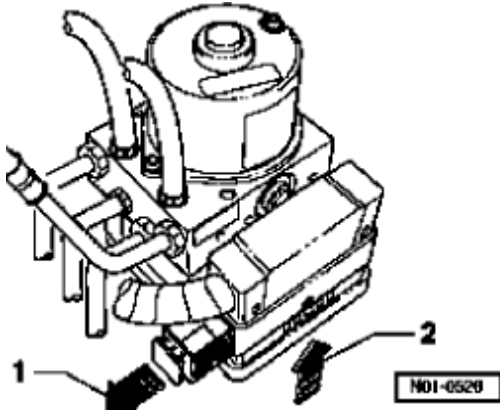

- Release control module connector (arrow -1-) and pull off (arrow -2-).
- Install brake pedal loading device VAG 1869/2.
- Connect bleeder bottle hose to left front brake caliper and left rear caliper bleed screw and open bleed screws.
- Depress brake pedal at least **60 mm (2.36 inch)** with brake pedal depressor VAG 1869/2.
- Close left front and left rear caliper bleed screws.
- Do not remove brake pedal depressor VAG 1869/2 from brake pedal.
- Place sufficient lint-free cloths under the control module and hydraulic unit. Make sure no brake fluid gets onto contacts.

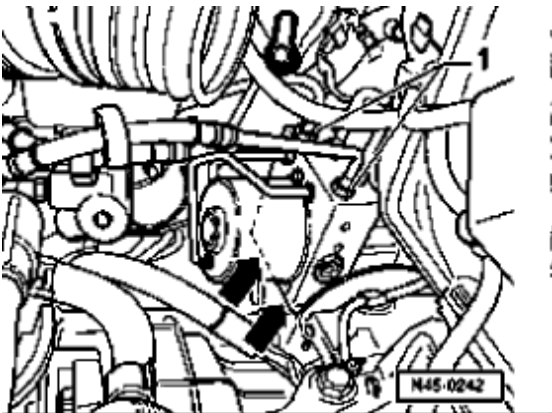

- Disconnect brake lines -1- from hydraulic unit to brake master cylinder and tie up
- Disconnect remaining brake lines on hydraulic unit.
- Seal brake lines and threaded holes with plugs from repair set Part No. 1H0698311 A.
- Remove bolts -arrows- from hydraulic unit/control module bracket.
- Remove hydraulic unit with control module.

Removing control module from hydraulic unit.

- Place the hydraulic unit with control module down on a clean flat surface.

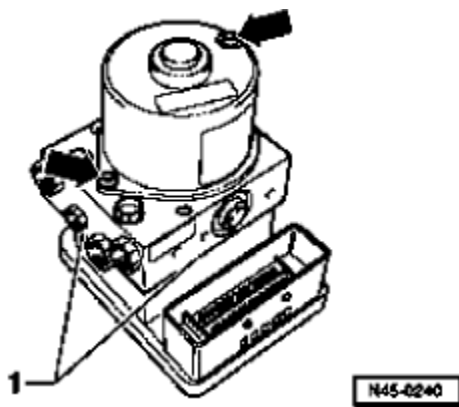

- Remove E 5 hex socket head bolt -arrows- from hydraulic pump.

CAUTION: The hydraulic pump must not be separated from the hydraulic unit.

- Separate hydraulic unit with hydraulic pump from control module by lifting carefully off joint -1-.

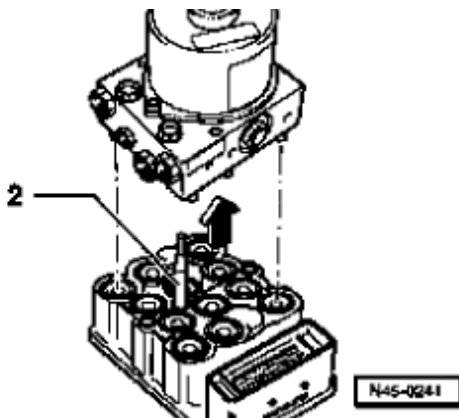

When pulling off control module, make sure that the hydraulic unit valve dome does not contact the control module solenoid valves.

Cover control module magnetic coils with a lint-free cloth.

After separating control module and hydraulic unit use transportation protection for valve dome.

The contact pin -2- which is supplied as a replacement part along with the control module can only be clipped in once and then it cannot be removed.

Installing

Note:

- Only remove sealing plugs on new hydraulic unit when the corresponding brake line is going to be installed

brake line is going to be installed.

- If the sealing plugs are removed too early, brake fluid can escape, it can no longer be guaranteed that the module is sufficiently filled or adequately bled.

When assembling the control module and hydraulic unit, be sure that the hydraulic unit valve dome does not come in contact with the control module solenoid valves.

- Using new bolts, install control module to hydraulic unit. Do not tighten more than a max. **4 Nm (35 inch lbs.)** .
- Bolt ABS module to bracket. Do not tighten bolts completely. Attaching the individual brake lines is made easier.
- After tightening brake lines, tighten hydraulic unit.
- Further installation is carried out in the reverse sequence.
- Remove brake pedal depressor VAG 1869/2.
- Bleed brake system
- Enter radio code.
- Code ABS control module (w/EDL) -J104-.
- Basic settings must be performed when replacing ABS control module (w/EDL) -J104-.

Tightening Torques:

Control module to hydraulic unit max.	4 Nm (35 inch lbs.)
Hydraulic unit to bracket	8 Nm (70 inch lbs.)
Nut for brake master cylinder to brake booster	20 Nm (15 ft. lbs.)
Brake lines at ABS module:	
Thread M 10 x 1	14 Nm (10 ft. lbs.)
Thread M 12 x 1	14 Nm (10 ft. lbs.)
Cap nut to body	20 Nm (15 ft. lbs.)

A.S.I. www.autoecu.com 1-866-983-6688

To ship to us visit our website and print our R&R form , Complete the form and include it with your part then ship to our address on the form.

Thank You